

**CLASS I APPLICATIONS**  
2 Cubic Feet Maximum  
**CLASS II APPLICATIONS**  
10 Cubic Feet Maximum

# MODEL 1011

## TYPE Z UNIVERSAL

### PRESSURIZATION / PURGING SYSTEM

### INSTALLATION & OPERATION MANUAL



Pepperl+Fuchs® Inc. • Telephone (330) 486-0002 • FAX (330) 425-4607 • E-mail: sales@us.pepperl-fuchs.com • www.bebcoeps.com

"Terms & Conditions of Sale" information is printed on every order acknowledgement; copies are available upon request.

We reserve the right to make modifications and no guarantee of the accuracy of the information contained herein is given.

© 2004 Pepperl+Fuchs® Inc., Twinsburg, Ohio  
512083, Dwg No. 129-0205 (Supersedes 1011-IOM) Printed in U.S.A.

## Table of Contents

<b>Page 2</b>	<b>System Purpose and Description</b> Purpose, System Description, Important Notes	<b>Page 11</b>	<b>Pneumatic Tubing Requirements</b> Protective Gas Supply Requirements, Pneumatic Connection Requirements
<b>Page 3</b>	<b>Identifying Your System</b> Defines specific features of the system	<b>Page 12</b>	<b>Tubing Installation</b> LH, RH, TM, BM, FM & PM Tubing Configurations
<b>Page 4</b>	<b>General Information</b> System & Material Specifications, System Accessories, Spare Parts, Tools & Test Equipment	<b>Page 13</b>	<b>Tubing Connection Diagrams</b> LH, RH, TM, BM, FM, & PM Configuration Connection Points, Pneumatic Diagram
<b>Page 5</b>	<b>Enclosure and Device Design</b> Design Requirements, Adjacent Enclosures, Device Ventilation, Temperature Limitations	<b>Page 14</b>	<b>Electrical Supply Requirements</b> Wiring Requirements, Enclosure Power & Alarm Signal, Enclosure Wiring Methods & Connections
<b>Page 6</b>	<b>Installation Overview</b> Installation Diagram	<b>Page 15</b>	<b>Set-Up Procedure</b> Class I & Class II Set-up
<b>Page 7</b>	<b>Getting Started</b> Establishing Connection Sizes, Determining Enclosure Inlet & Outlet Connection Locations	<b>Page 16</b>	<b>Operating Sequence</b> Class I & Class II Operation
<b>Page 8</b>	<b>System Mounting</b> LH, RH, TM & BM Configurations, FM & PM Configurations	<b>Page 17</b>	<b>Trouble - Shooting Procedures</b> Trouble-shooting Chart
<b>Page 9</b>	<b>Mounting Plate Dimensions</b> Mounting Plate Dimension Diagrams	<b>Page 18</b>	<b>Warranty and Liability Statement</b> Warranty Notes, General Terms, Limitations
<b>Page 10</b>	<b>Hardware Mounting</b> Optional Enclosure Protection Vent, Warning Nameplates	<b>Page 19</b>	<b>System Maintenance</b> Regular Maintenance, Long Term Maintenance, Maintenance Schedule
		<b>Page 20</b>	<b>Systems Identification &amp; Application Information</b>

### Purpose

Pepperl+Fuchs Enclosure Protection System's purpose is to allow the use of general purpose or non-rated electrical or electronic devices, with exception to devices which produce excessive heat, utilize combustible gas, or expose arcing contacts to the hazardous atmosphere, in Type 4 or 12 enclosures in the place of explosion proof Type 7 enclosures. Other purposes include heat, moisture and dust contamination prevention.

### Description

Model 1011 is an enclosure pressurization or purging system that operates on a supply of compressed instrument air or inert gas. It regulates and monitors pressure within sealed (protected) enclosures, to prevent combustible dust accumulation or remove and prevent flammable gas or vapor accumulations. In Class II areas, the system maintains a "safe" (1.0") pressure. In Class I areas, the system accomplishes four air exchanges and maintains a "safe" (0.25") pressure. These processes reduce the hazardous (classified) area rating within the enclosure(s), in accordance with the NEC - NFPA 70, Article 500, NFPA 496 and ISA12.4

### Important Notes

One (1) permanent file copy and one (1) operations copy of this Manual must be studied and retained by the operator of this System. User's Agents are responsible for transferring this Manual to the user, prior to start-up.

The contents of this manual have been arranged to allow the use of this product as a stand-alone device on equipment and enclosures supplied by the user or its agents. The Manual's parameters encompass a combination of both National Fire Protection Association (NFPA) requirements and Pepperl+Fuchs requirements. Pepperl+Fuchs therefore acknowledges the use of NFPA 496 as a guideline, that we have enhanced certain NFPA requirements and that additional information has been compiled to complete this document. The Manual is intended as a complete guide and must be considered, unless specifically stated otherwise, that all directives contained herein are Pepperl+Fuchs requirements for safe, practical and efficient use of this product.

This System is not intended for use to protect enclosures or devices which contain ignitable concentrations of gases or vapors. This exclusion generally applies to process or product analyzing systems equipment.

**All specifications are subject to change without notice.**

# Identifying Your System

This Enclosure Protection System is offered in various styles. For proper installation and operation, examine the System Model Number Nameplate to identify the System Style, Area Classification, and Type, as noted below.

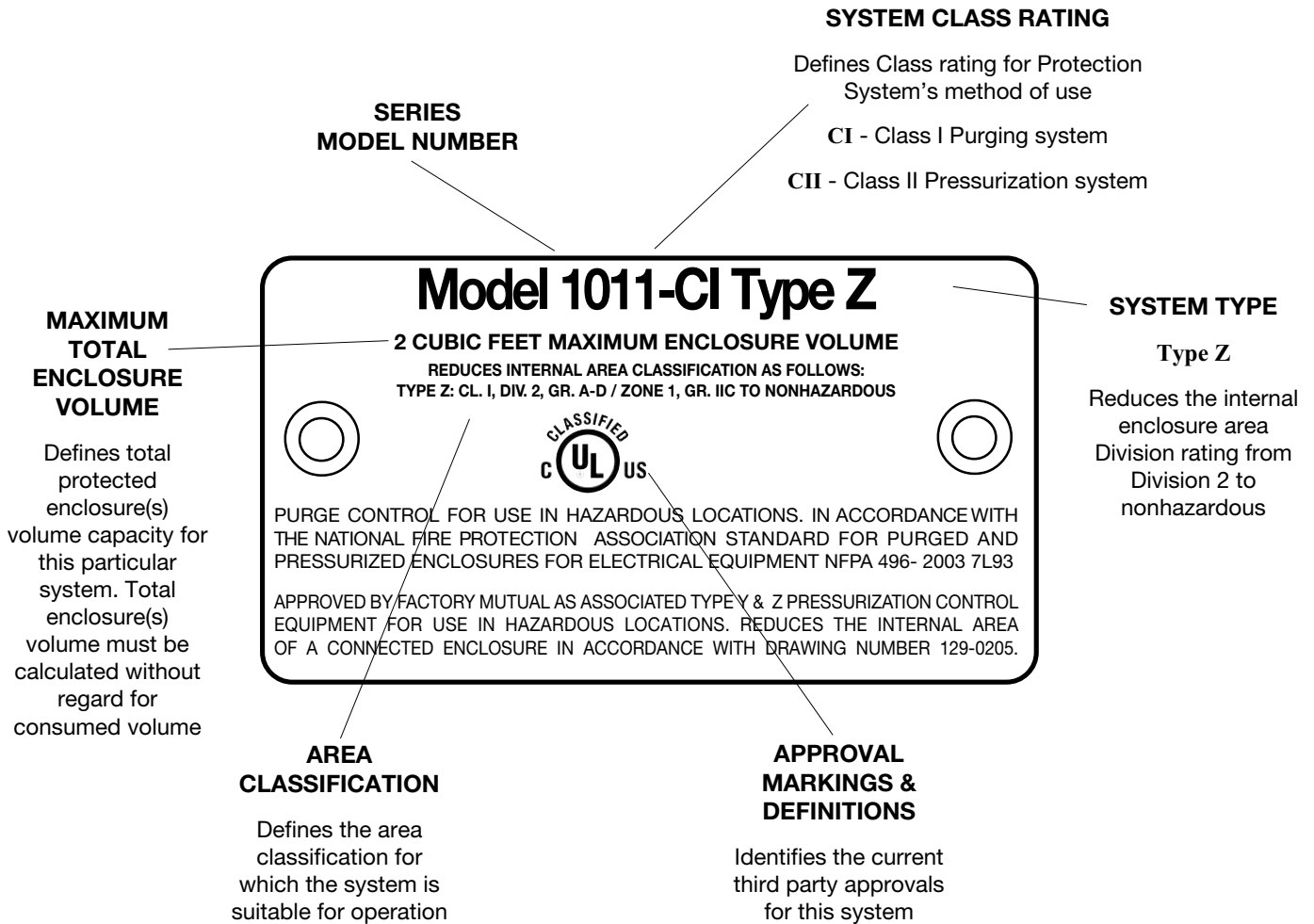

To assist you through the installation and operation of your pressurization / purge system, Pepperl+Fuchs, has provided the following information boxes throughout this manual. This information is intended to clarify certain differences between the model styles and configurations and to warn the user / installer of potential dangers of electrical shock or enclosure over pressurization.

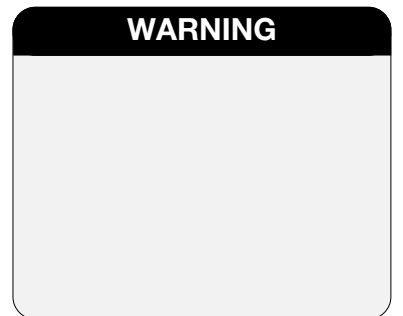

# General Information

## System Specifications

System Dimensions:	See Page 9
Shipping Weight ( lbs.):	7
Operating Temperature Range:	-20° F - 120° F
Supply Pressure Range:	* 5 -120 PSI max.
Supply Requirements:	Clean Air or Inert Gas
Safe Pressure (CI/CII):	0.25" / 1.0"
Safe Pressure Flowrate:	** 0.1-3.5 SCFH/Cubic Ft.
System Supply Fitting:	1/4" Tube Fitting
Enclosure Supply Fitting:	1/4" Tube Fitting
Enclosure Reference Fitting:	1/4" Tube Fitting

- \* With Enclosure Protection Vent - 120 PSI maximum  
Without Enclosure Protection Vent - 5 PSI maximum

In order to comply with the NFPA 496 standard requiring protection against over pressurization of the protected enclosure, the installer must install one of the following items in addition to the enclosure protection system.

- Install an Enclosure Protection Vent on the protected enclosure.
- Install a tamper-proof regulator upstream of the enclosure protection system's system supply inlet to pre-regulate protective gas supply to 5 PSI max.

In addition, for small, tightly sealed enclosures, or to compensate for a fluctuating protective gas supply, it may be necessary to pre-regulate the protective gas supply to a constant 5 PSI regardless of whether an Enclosure Protection Vent is installed. This will reduce the amount of "drifting" that can normally occur when maintaining a "Safe" pressure inside a protected enclosure. The pre-regulation can be accomplished by installing a TR-10G Tamper-Proof Regulator accessories or equivalent.

For applications which require a steady "Safe" pressure setting or for protective gas supplies which may have dramatic pressure fluctuations, it may be necessary to utilize the PR-10 or PR-10G self relieving Precision Regulators or equivalent to pre-regulate the protective gas supply to a constant 5 PSI (please consult factory for more information).

- \*\* Enclosure integrity determines actual flow rate

## Material Specifications

Regulator Body:	Zinc w/ Enamel Finish, Brass
Regulator Handle:	Polycarbonate
Enclosure Pressure Gauge:	Alum. w/ Enamel Finish
Tube Fittings:	316 SS Forged Body
Tubing:	316 SS 1/4" .035 Welded
System Nameplates:	Silkscreen & Lexan®
Fastener Hardware:	Aluminum & Stainless Steel
Mounting Plate & Bracket:	Anodized Aluminum

Lexan® is a registered trademark of the General Electric Corporation

## Recommended Spare Parts

Qty	Description	Part # (supercedes)
1	Enclosure Pressure Indicator-CI	510023 (001000)
1	Enclosure Pressure Indicator-CII	513235 (001027)
1	Enclosure Pressure Control Regulator	513315 (002000)
1	Installation & Operation Manual	129-0205
1	Enclosure Warning Nameplate-CI	513008 (EWN-1)
1	Enclosure Warning Nameplate-CII	513009 (EWN-2)

Please call and reference part number above for current spare parts pricing. Immediate pricing is available to all confirmed customers.

## Installation Tools & Testing Equipment

1/2" chuck drill  
Complete set of drill bits  
1/2" conduit knockout punch or 0.875" hole saw  
Complete set of tubing, conduit bending, instrument fitting and electrical craftsman hand tools  
0 - 250 scfh flowmeter (connected upstream of the Protection System to determine air consumption and flow during set-up procedure)

## Model 1011 System Accessories

### Optional Enclosure Protection Vents

EPV-1-SA-00	Straight w/ Spark Arrestor
EPV-1-SA-90	Rt Angle w/ Spark Arrestor

### Additional Items

SMK-1, or -4	System Mounting Kit
EPSK-1	Class I, Group C - D Pressure Switch Kit
EPSK-1A	Class I, Group A - D Pressure Switch Kit
EPSK-2	Class II, Group E - G Pressure Switch Kit
GPSK-1	Class I, General Purpose Switch Kit
GPSK-2	Class II, General Purpose Switch Kit
RAH	Div. 1 Remote Alarm Horn
RAB-1	Div. 1 Remote Alarm Beacon
RAB-2	Div. 2 Remote Alarm Beacon
LCK	L Fitting Conduit Kit
TCK	T Fitting Conduit Kit
TR-10G	Tamper-Proof Regulator w/ Gauge
PR-10	Precision Regulator
PR-10G	Precision Regulator w/ Gauge

# Enclosure & Device Design

## Enclosure Design Requirements

1. All windows must be shatterproof and sized as small as possible.
2. All NFPA 496 required markings must be placed on or near **all** enclosure doors and covers.
3. The enclosure must withstand an internal pressure of ten (10) inches of water without sustaining permanent deformation and resist all corrosive elements in the surrounding atmosphere.
4. All lightweight objects in the enclosure, such as paper or insulation, must be firmly secured.
5. The enclosure should be constructed from materials such as metal or anti-static polycarbonate to meet or exceed Type 4 or 12 performance requirements, but does not require third party approval.
6. The installation of obstructions or other barriers which block or impede the flow of protective gas must be avoided.
7. The creation of air pockets or other areas which trap flammable gases within the enclosure or devices must be avoided.
8. The enclosure should be located in an area where impact hazards are minimal.
9. If the enclosure is nonmetallic and contains equipment which utilizes or switches power loads greater than 2500 VA, it must be constructed from substantially noncombustible materials, such as materials designed to meet or exceed ANSI/UL94 ratings of 94 V-0 or 94 5V.

## Adjacent Enclosures

1. Adjacent enclosures must be protected by one of the following means:
  - a) purged or pressurized in series with the protected enclosure;
  - b) purged or pressurized separately; or
  - c) protected by other means; e.g. explosion proof enclosures, hermetically sealed devices or intrinsic safe circuits.
2. Adjacent purged or pressurized enclosures must be designed to meet all construction requirements above.

## Total Volume Calculation

1. The total volume of all pressurized enclosures, devices and wireways must be considered.
2. All enclosure, device and wireway volumes must be calculated without consideration of internally consumed space.

## Device Ventilation

1. Enclosed devices within the protected enclosure which do not exceed 1.22 cubic inches of free volume do not require ventilation to the protected enclosure.
2. If the free volume of an internal device exceeds 1.22 cubic inches it must be protected by one of the following means:
  - a) ventilated on the top and bottom sides with one (1) square inch of opening for each four hundred (400) cubic inches of volume within the internal protected enclosure, at a minimum diameter of one (1) quarter inch;
  - b) purged in series with the protected enclosure or be purged separately; or
  - c) protected by other means; e.g. explosion proof enclosures, hermetically sealed devices or intrinsic safe circuits.

## Temperature Limitations

1. The enclosure must have no surface area which exceeds 80 percent of the flammable or ignitable substance's auto-ignition temperature.
2. Internal devices which exceed this temperature must be protected by one of the following manners.
  - a) The device is enclosed in a chamber which is cUL listed as a hermetically sealed device which prohibits the entrance of flammable or ignitable substance, and maintains a surface temperature below temperature limits.
  - b) It can be proven by testing that the devices will not ignite the substance involved.
  - c) The device is purged in a separate enclosure that bears an ETW (Enclosure Temperature Warning Nameplate). Devices may only be accessed after power has been removed and the device has been allowed to cool to safe temperature, or the area is positively known to be nonhazardous.

# Installation Overview

## Typical Left Hand Configuration Installation Diagram

Model 1002-WPS-LH Shown

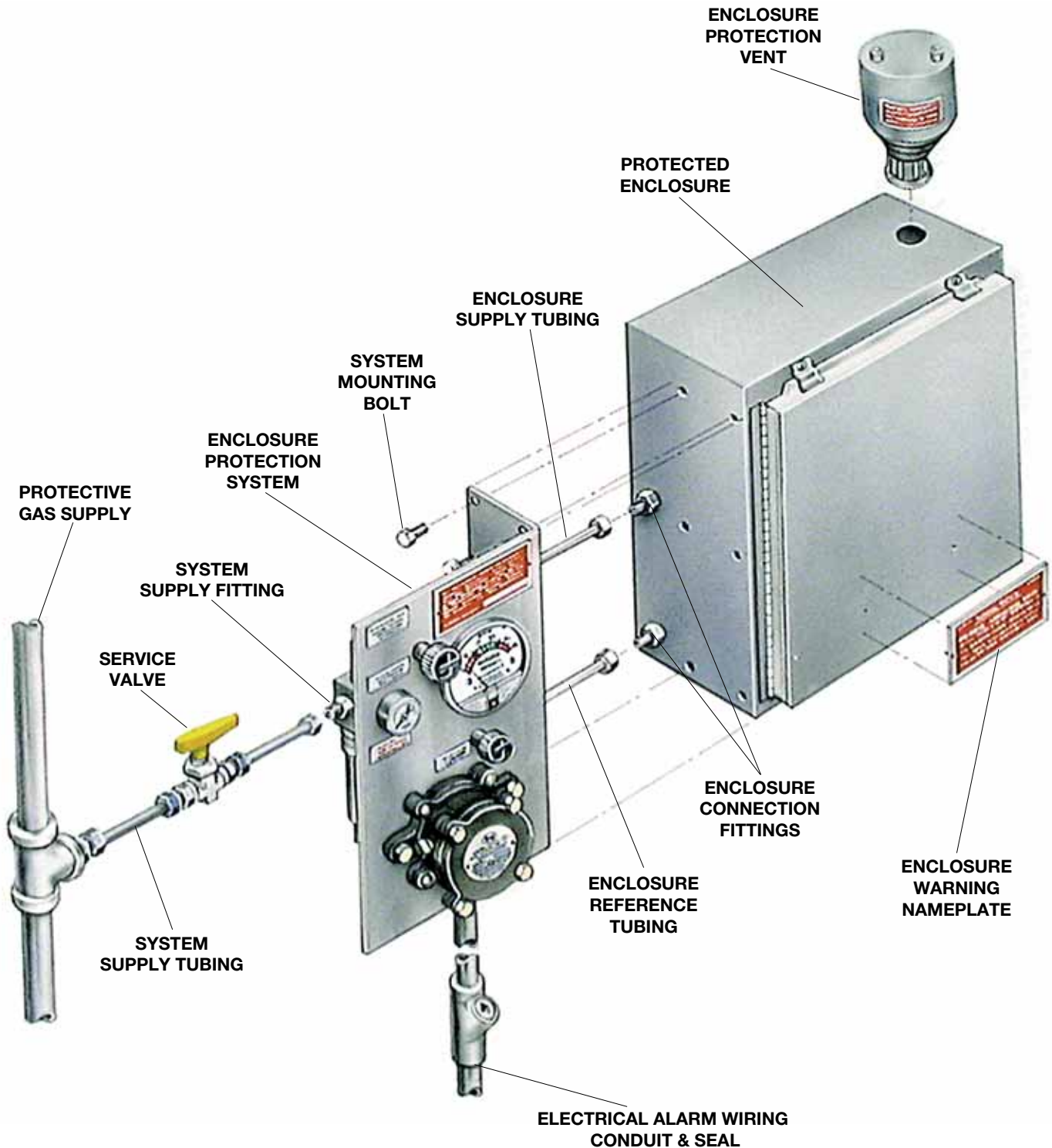

# Getting Started

## Establishing Connection Sizes, Lengths & Bends

### TYPICAL SINGLE PROTECTED ENCLOSURE CONNECTIONS

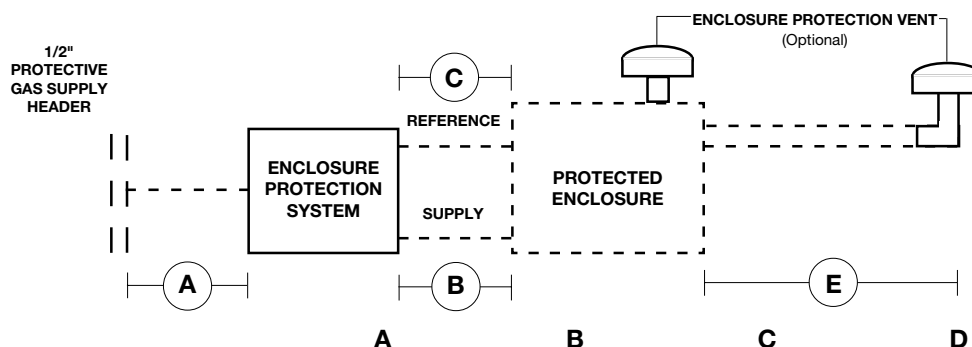

Description	System Supply Tubing	Enclosure Supply	Enclosure Reference	Multi - Enclosure Connections	Optional Remote Venting
*Tubing or Pipe Diameter	1/4" O.D. Tubing Fully Reamed	1/4" O.D. Tubing Fully Reamed	1/4" O.D. Tubing Fully Reamed	1/2" I.D. Pipe Fully Reamed	1/2" I.D. Pipe Fully Reamed
Maximum Tubing / Pipe Length and Maximum Number of Bends / Elbows	20 Feet 10 Bends	5 Feet 5 Bends	20 Feet 10 Bends	10 Feet 5 Elbows	30 Feet 5 Elbows

### TYPICAL MULTIPLE PROTECTED ENCLOSURE CONNECTIONS

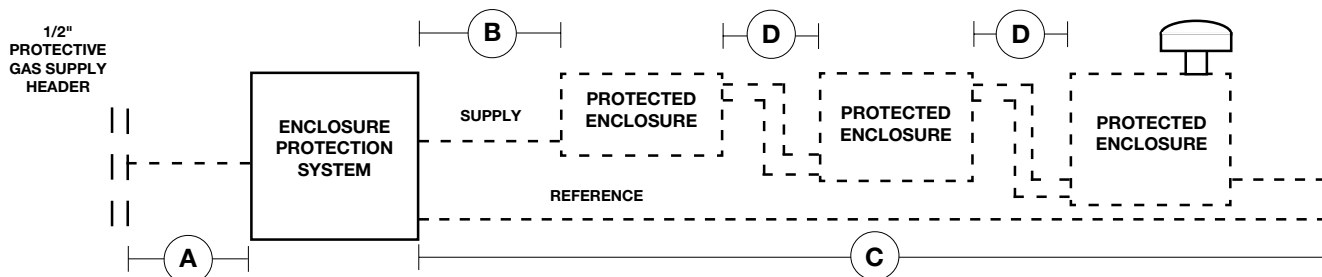

**\*NOTE:** Tube and pipe sizes are not equal in inside diameters.  
DO NOT substitute tube for pipe with same trade size.

### HELPFUL HINTS

To ensure adequate protective gas flow to the protected enclosure(s), all piping and tubing must be fully reamed. Precautions must be taken to prevent crimping and other damage to protective gas piping and tubing. When protecting multiple enclosures with a single enclosure protection system, the enclosures must be connected in series from the smallest to the largest to ensure adequate protective gas flow.

### Determining Enclosure Inlet & Outlet Connection Locations

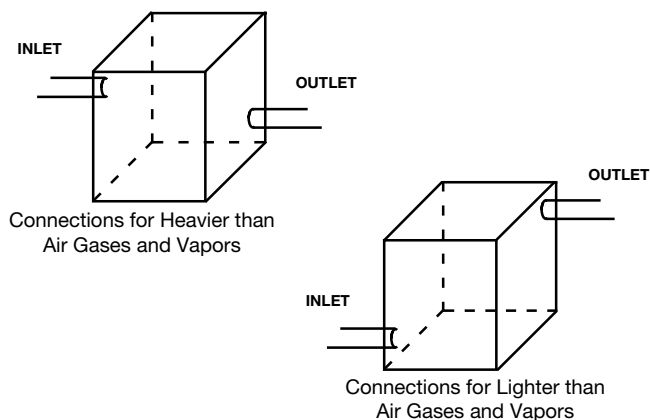

### HELPFUL HINTS

If flammable gases are lighter than air, the inlet connection to each enclosure must enter near a bottom corner. The outlet connection, for an optional enclosure protection vent or piping to an adjacent protected enclosure, must exit near an extreme opposite top corner.

If flammable gases are heavier than air, inlet and outlet connections must be reversed.

In all cases, the most prevalent gas must determine the location of inlet and outlet connections.

# System Mounting

## IMPORTANT NOTES

The system should be mounted at **EYE LEVEL**.

Care must be taken to ensure the system and all protruding components are clear of all enclosure accesses (doors and covers) and conduit, pipe, tubing or cable entries.

LH, RH, TM and BM configurations are intended for mounting adjacent to the protected enclosure.

Determine the mounting configuration for your application using the diagrams on page 9.

Remove and save the manila envelope (containing the enclosure warning nameplate) which may be taped to the System mounting bracket.

Although all systems are factory tested and calibrated, we strongly suggest a bench test of basic functions prior to installation.

## Mounting LH, RH, TM, & BM Configurations

1. Determine the mounting configuration for your application using the diagrams on page 9.
2. Secure the System mounting bracket to the appropriate edge of the system mounting plate using the hex head set screws provided with the system.
3. Transfer hole pattern of System mounting bracket to intended surface.
4. Check for obstructions hindering bolt fastening, drill and ream the mounting holes before mounting the system.
5. Secure the system to the enclosure, or other mounting surface, using the fastening hardware provided.

## Mounting FM & PM Configurations

1. Carefully read the HELPFUL HINTS located below.
2. Transfer panel cutout pattern to the intended surface.
3. Check for obstructions which could prohibit bolt fastening or system pneumatic connections.
4. Cut panel cutout pattern on the intended surface.
5. Deburr all cutout surfaces.
6. Secure system to enclosure using SMK-4, or equivalent 1/4" x 3/4" stainless steel nuts, bolts, mounting clips and lock washers.

## HELPFUL HINTS

FM and PM configurations are designed to mount through a panel cutout one (1) inch smaller than the overall height and width of the system mounting plate, using clips and fasteners provided with the SMK -4 mounting kit. This design feature eliminates the need to drill the system mounting bolt holes in the protected enclosure.

FM configurations are intended for mounting adjacent to the protected enclosure.

PM configurations are intended for mounting through a cutout in the protected enclosure surface.

## Typical Examples of Surface, Panel & Frame Mounted Systems



Typical Surface Mounted System  
(Model 1002-LPS-CI-Z-LH shown)



Typical Panel/Frame Mounted System  
(Model 1002-LPS-CI-Z-LH shown)

# Mounting Plate Dimensions

## Model 1011

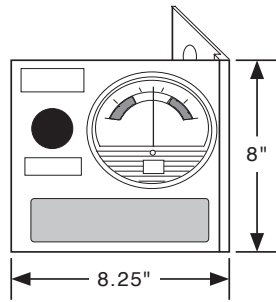

**1011-LH**  
(Left Hand Configuration)

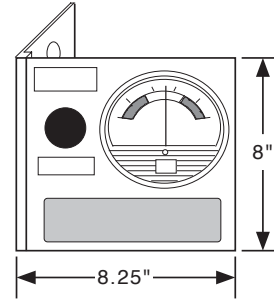

**1011-RH**  
(Right Hand Configuration)

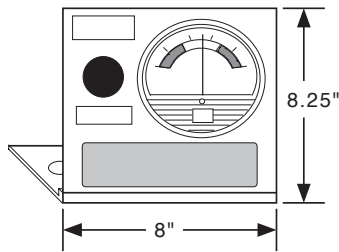

**1011-TM**  
(Top Mount Configuration)

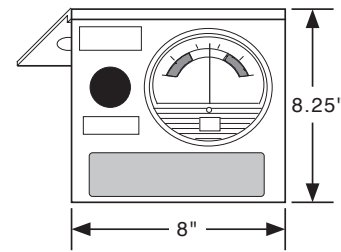

**1011-BM**  
(Bottom Mount Configuration)

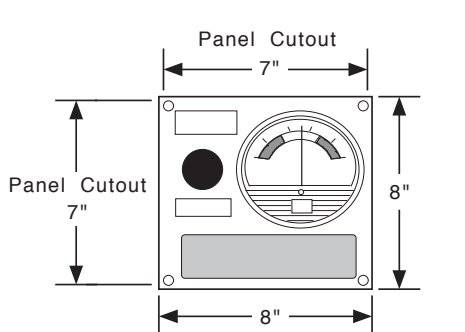

**1011-FM & 1011-PM**  
(Frame & Panel Mount Configuration)

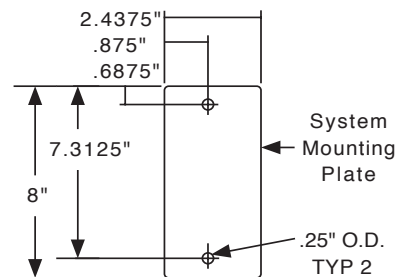
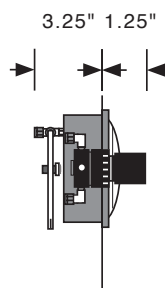

**Universal Mounting Bracket**

# Hardware Mounting

## Optional Enclosure Protection Vent

All configurations must be mounted in a true vertical position.

The vent must be located to provide access for routine testing of the vent's flapper assembly. A minimum 8" clearance is required below the vent opening.

1. Determine the vent's mounting configuration, i.e.; -00 vertical mount or -90 side mount. (see photos below)
2. Determine vent location and layout vent mounting hole on the protected enclosure. (as determined on page 7, "Getting Started")
3. Using a 0.875" hole saw or 1/2" conduit punch, drill and deburr the enclosure protection vent mounting hole.
4. Remove the hub mounting nut from the vent hub and place the hub, with O-ring intact, through the mounting hole. The O-ring must be on the outside of the protected enclosure.
5. Reinstall the hub mounting nut to the mounting hub from inside the protected enclosure and tighten.



EPV - 1 - SA - 00  
Vertical Mount



EPV - 1 - SA - 90  
Side Mount

## Warning Nameplate(s)

An EWN (Enclosure Warning Nameplate) must be located in a prominent position on or near **all** enclosure accesses (doors and covers).

One (1) EWN is provided with each system, located in the manila envelope taped to the mounting flange of the system. Additional EWN's are available from Pepperl+Fuchs.

All EWNs provide labeled spaces allowing the customer to mark the protected enclosure with: 1) a T Code (temperature identification number), 2) Class, Group and Division of surrounding area, and 3) NFPA pressurization Type X, Y or Z, as may be required by plant and local codes and is required by NFPA 496.

An ETW (Enclosure Temperature Warning nameplate) must be located in a prominent position on or near all enclosure accesses (doors and covers) when the temperature of an internal component exceeds 80 percent of the ignition temperature of the flammable vapor, gas or dust involved.

An ETW warns the operator to deenergize all equipment for a specified length of time, allowing the protected equipment to cool before opening the protected enclosure. The length of time required is determined by the customer and can be factory or field engraved.

All EWNs and ETWs are furnished with an adhesive back, but should also be riveted or screwed to the protected enclosure.



Enclosure Warning Nameplate - Class I



Enclosure Warning Nameplate - Class II



Enclosure Temperature Warning Nameplate

# Pneumatic Tubing Requirements

## Protective Gas Supply Requirements

The protective gas supply to the protection system must be a clean, instrument quality compressed air or nitrogen and must contain no more than trace amounts of flammable gas, vapor or dust.

The protective gas supply compressor intake must originate in a nonhazardous location. Suction duct passing through a hazardous location and the protection system tubing and piping must be fabricated from noncombustible materials suitable for prevailing hazards and environmental conditions.

The protective gas supply must originate from a dedicated instrument quality compressed air header (1/2" pipe or larger), no farther than twenty (20) feet from the protection system. Local compressors and gas cylinders should not be used before consulting with Pepperl+Fuchs.

The protective gas supply to the protection system must be equipped with a tamper-proof regulator set at 5 psi maximum.

**Exception:** If the protected enclosure(s) is equipped with an Enclosure Protection Vent, the protective gas supply to the protection system must not exceed 120 psi maximum, 5 psi minimum. (See page 4, "System Specifications" for additional information concerning protective gas supply requirements.)



SC-4



NC-4

### SYSTEM SUPPLY FITTINGS



EFC-4



EBC-4

### ENCLOSURE SUPPLY & REFERENCE FITTINGS



EPC-10

### MULTIPLE ENCLOSURE CONNECTION FITTING

## Pneumatic Connection Requirements

ALL FITTINGS MAY BE CUSTOMER OR FACTORY FURNISHED

1. For system supply, one (1) SC-4 1/4" Male Straight Connector or one (1) NC-4 1/4" Male Elbow Connector or equivalent fitting per system.

**NOTE: Above fitting is required only if protection system is furnished with an optional In Line Filter Kit (Model ILFK) accessory.**

One (1) Similar fitting which will connect the inert gas supply tubing to the inert gas supply header connection point and one (1) lot of 1/4" O.D., .035" wall thickness, welded or seamless stainless steel tubing.

2. For enclosure supply, one (1) EFC-4 1/4" Flush Connector, or one (1) EBC-4 1/4" Feed-Through Connector or equivalent fitting per system.
3. For enclosure reference, one (1) EFC-4 1/4" Flush Connector, or one (1) EBC-4 1/4" Feed-Through Connector or equivalent fitting per system.
4. One (1) lot of 1/4" O.D., .035" wall thickness, welded or seamless stainless steel tubing.
5. For multiple enclosure connections, two (2) EPC-10 1/2" Pipe Mounting Hubs or equivalent and 1/2" 150# rated pipe couplings & unions per interconnection.

One (1) lot 150# rating 1/2" galvanized or aluminum pipe and fittings, fully reamed and unrestricted.

## PM Pneumatic Connection Requirements

In addition to item numbers 1, 4 and 5 above, the following fittings are required for all PM configurations.

1. For system supply on PM configurations, one (1) additional EBC-4 or equivalent 1/4" Through Bulkhead Fitting per system is required.
2. For atmospheric reference, one (1) PRB-4 or equivalent 1/4" female bulkhead fitting and stainless steel sintered element is required.



PRB-4

### SYSTEM ATMOSPHERIC REFERENCE FITTING

# Tubing Installation

## HELPFUL HINTS

All work must be performed by technicians qualified in pneumatic tubing and electrical conduit installation.

Pepperl+Fuchs recommends the use of .035" wall thickness, welded or seamless stainless steel tubing. If flexible tubing is used, it must be installed in a manner which will protect it from damage and corrosion.

## Tubing LH, RH, TM, BM & FM Configurations

### System Supply Connections

1. Select or install a protective gas supply header tap, fitted with the proper tube size fitting and located within twenty (20) feet of the enclosure protection system.
2. If a service valve is placed between the protective gas supply header and the enclosure protection system, it must be installed in close proximity of the protected enclosure and be labeled in accordance with NFPA 496, 2003 edition.
3. Select the appropriate fittings required to connect the protective gas supply to the protection system regulator as determined on page 11, "Pneumatic Connection Requirements".
4. Determine appropriate tubing route from the protective gas supply header to the protection system regulator.
5. Bend tubing using industrial grade benders, check tubing fit to ensure proper seating between the tubing and fittings. Fully ream all tubing ends.
6. Install tubing and tighten all fittings to fitting manufacturer's specifications. Secure tubing to appropriate structural supports as required.

### Enclosure Supply & Reference Connections

1. Choose location for the enclosure supply connection(s) based on the requirements on page 7, "Getting Started".
2. Place the enclosure reference connection fitting directly behind the enclosure protection system whenever possible. For systems protecting multiple enclosures in series, the enclosure reference connection fitting must be placed on the last enclosure in the series. (see page 7, "Getting Started")
3. Drill and deburr enclosure supply and reference fitting holes on the protected enclosure. Mount the fittings.
4. Determine appropriate route for the enclosure supply and reference tubing.
5. Bend tubing using industrial grade benders, check tubing fit to ensure proper seating between the tubing and fittings. Fully ream all tubing ends.
6. Install tubing and tighten all fittings to fitting manufacturer's specifications. Secure tubing to appropriate structural supports as required.

## Tubing PM Configurations

### Enclosure Bulkhead Fittings

1. Select the fittings required to install the System Supply, System Supply Bulkhead Fitting and Atmospheric Reference Bulkhead Fitting, (see page 11, "Pneumatic Tubing Requirements").
2. Choose location for the system supply bulkhead fitting. This fitting allows the protective gas supply to pass through the wall of a protected enclosure to the protection system's regulator supply inlet connection.
3. Choose location for the atmospheric reference bulkhead fitting. This fitting allows the enclosure pressure gauge to reference atmospheric pressure.
4. Drill and deburr system supply and reference bulkhead fitting holes in the protected enclosure. Mount the fittings.

### System Supply & Reference Connections

1. Select or install a protective gas supply header tap, fitted with the proper tube size fitting and located within twenty (20) feet of the enclosure protection system.
2. If a service valve is placed between the protective gas supply header and the protection system, it must be in close proximity of the protected enclosure and labeled in accordance with NFPA 496.
3. Determine appropriate tubing route from the protective gas supply header to the system supply bulkhead fitting.
4. Determine appropriate tubing route from the system supply bulkhead fitting to the protection system regulator.
5. Determine appropriate tubing route from the atmospheric reference bulkhead fitting to the enclosure pressure gauge's reference inlet connection.
6. Bend tubing using industrial grade benders, check tubing fit to ensure proper seating between the tubing and fittings. Fully ream all tubing ends.
7. Install tubing and tighten all fittings to fitting manufacturer's specifications. Secure tubing as required.

# Tubing Connection Diagrams

## LH, RH, TM, BM & FM Configuration Connection Points & Pneumatic Diagram



Top Mount Configuration

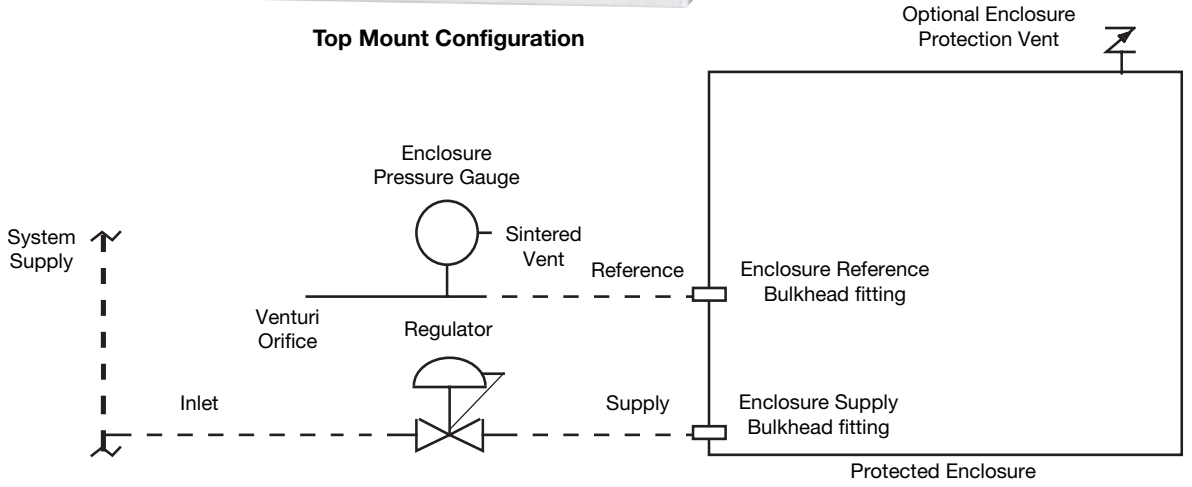

## PM Configuration Connection Points & Pneumatic Diagram

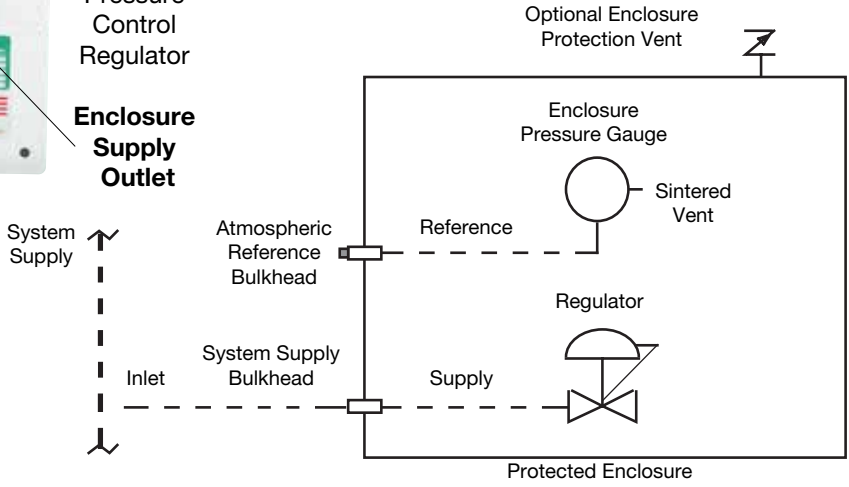

**HELPFUL HINT**  
Pneumatic Connections are bolded.

# Electrical Supply Requirements

## General Wiring Requirements

### WARNING

**THIS DEVICE CONTAINS ELECTRICAL PARTS WHICH CAN CAUSE SHOCK OR INJURY**

All electrical connections, conduit and fittings on the protected enclosure must be suitable for the hazardous location in which they are installed. In addition, all conduit and wire must be installed in accordance with NEC as required and all relevant plant and local codes.

**Note:** Do not use seals on conduit used as a protected “wireway” to supply protective gas to adjacent protected enclosures. The same conduit can be utilized for both electrical and pneumatic service to an adjacent protected enclosure(s), provided the conduit is oversized to allow a minimum free clearance equal to or larger than the pipe size required between multiple enclosures as stated on page 7, “Getting Started”.

## Enclosure Power Requirements

The protected enclosure(s) electrical power source must originate from a circuit breaker or fused disconnect suitable for the hazardous location in which it is installed. The switch must be located within fifty (50) feet of the protected enclosure(s) and the protection system and be properly marked.

## Alarm Signal Requirements

For Type Y and Z purge systems, audible alarms or visual indicators must be used to notify operators that pressure inside the enclosure is below the NFPA minimum.

Alarms are connected directly to the enclosure and monitor the differential air pressure between the enclosure and the environment outside it. These alarms are activated by the reduction in flow or pressure within the protective enclosure and have a direct connection to the enclosure, eliminating the need for an alarm on the protective gas supply.

- The alarm must be located where the operator can see it easily.
- The alarm must take its measurement from the enclosure only.
- Alarms located in the hazardous area must be rated for the area.
- Valves cannot be connected between the alarm and the enclosure.

### IMPORTANT NOTE

**NFPA 496 requires the use of an alarm or an indicator to detect the loss of safe enclosure pressure. In addition, the NFPA 496 requires that if an indicator alone is utilized, a protective gas supply alarm must also be installed between the last valve in the protective gas supply and the protected enclosure. Therefore, the protective gas supply to all Model 1011 systems must be equipped with the above mentioned protective gas supply alarm. Exception: Systems utilizing an EPSK or GPSK enclosure pressure loss alarm switch accessory will satisfy the above mentioned NFPA requirement.**

## Typical Enclosure Wiring Methods

In a general sense, protected enclosures should be wired similar to explosion proof enclosures, in accordance with **Article 500** of the National Electric Code - **NFPA 70**.

Single conductor wiring should be placed in rigid metal conduit, seal-flex conduit or other mediums approved for use in the hazardous location surrounding the protected enclosure. Additionally, **NFPA 496** requires the use of approved seals on all pressurized enclosure conduit wiring entries, in accordance with **NFPA 70**. Furthermore, the use of an approved seal is simply the most practical way to prevent excessive leakage through conduit connections.

However, while explosion proof enclosures require conduit seals on all cable entries, in accordance with **NFPA 70**. Other methods of sealed cable entries that are suitable for hazardous locations can be used, such as compression glands.

In conclusion, there are two primary goals. First, the installer should ensure that all associated wiring and cable is protected by pressurization or other means, such as explosion proof conduit or intrinsic safety barriers. Secondly, the installer should ensure that all associated conduit and wireways are sealed to conserve protective gas, unless they are used to supply protective gas to other enclosures or devices.

## Typical Enclosure Wiring Connections

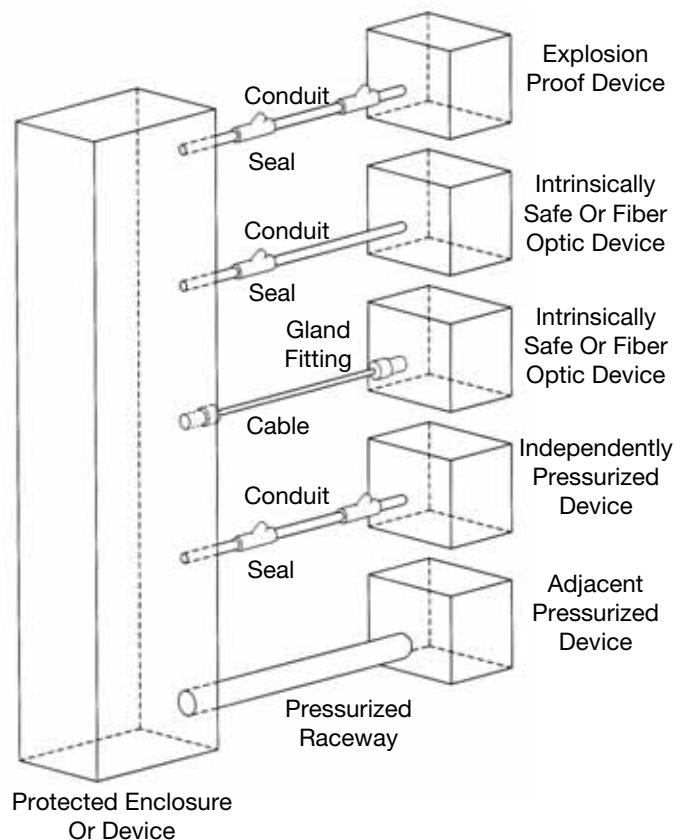

# Set-up Procedure

## HELPFUL HINTS

The term “Safe” pressure for purposes of this manual is defined as follows;

**Class I = a minimum .25 inch of water column pressure.**

**Class II = a minimum 1.0 inch of water column pressure.**

**Regulator may be in the locked position upon arrival.**

**To adjust regulator, pull handle to outward position.**

To test the vent’s operation, gently prod the vent flapper open with a soft pointed object, ( example: eraser end of a pencil) ensuring that the vent valve works freely. On vertically configured vents, this can be accomplished from within the protected enclosure. Side mounted -90 configured vents can be tested by removing the conduit plug at the bottom of the mounting tee. Multiple operations require only one test per day if enclosure is not opened or left unattended.

## Class I Purging Set-up

1. Close the Enclosure Pressure Control Regulator fully by turning counterclockwise (CCW).
2. Temporarily connect the inert gas supply to a 0 to 250 SCFH flowmeter. Connect the outlet of the flowmeter to the Enclosure Pressure Control Regulator.
3. Check operation of Enclosure Protection Vent (if utilized).
4. Seal enclosure(s) and adjust Enclosure Pressure Control Regulator by opening slowly clockwise (CW) to set a “Safe” pressure on the Enclosure Pressure Indicator.  
**NOTE:** If pressure setting is difficult to stabilize or set, (see page 17, “Trouble-Shooting Procedures”).
5. When safe enclosure pressure is stabilized, measure flow of inert gas supply through Protection System, to calculate required exchange time, based on the Class I exchange time chart.
6. Install and tighten all bolts on the pressure loss alarm switch (if utilized). Ensure the conduit is sealed with approved compounds. Energize power to Switch and alarm system (if utilized) and test the function of the alarm system.
7. Cease testing and remove test equipment (Flowmeter).
8. Connect the inert gas supply directly to the Enclosure Pressure Control Regulator.

### CLASS I VOLUME EXCHANGE TIME CHART

MEASURED FLOW	REQUIRED EXCHANGE TIME
0.10 SCFM / 6 SCFH	40 Minutes per Cubic Foot
0.25 SCFM / 15 SCFH	16 Minutes per Cubic Foot
0.50 SCFM / 30 SCFH	8 Minutes per Cubic Foot
0.75 SCFM / 45 SCFH	5.5 Minutes per Cubic Foot
1 SCFM / 60 SCFH	4 Minutes per Cubic Foot
2 SCFM / 120 SCFH	2 Minutes per Cubic Foot
3 SCFM / 180 SCFH	1.5 Minutes per Cubic Foot
4 SCFM / 240 SCFH or greater	1 Minute per Cubic Foot

**NOTE:** The volume exchange time chart is based on a four (4) enclosure volume exchange. Multiply the required exchange time above by 2.5 for applications requiring a ten (10) volume exchange (motors).

Regardless of enclosure volume or system flow rate, Pepperl+Fuchs requires that operators withhold power to the enclosure while inducing Class I exchange, for at least five (5) minutes. Normal exchange time calculations should be doubled if large obstructions block inert gas flow.

The Start-Up Instruction Nameplate Exchange Time Slot will be blank, but the unit may feature a set of direct factor nameplates with self-adhesive backing such as “TEN MINUTES”, for application to the start-up instructions, dependent on how the system was specified and purchased. Field modification of this nameplate, to show a direct factor, is acceptable as noted above if the method used to mark the nameplate does not deface the instructions listed. Materials used for the marking must be indelible and withstand prevailing environmental conditions.

## IMPORTANT NOTE

**Operators must secure wrist or stop watch to manually time Exchange Cycle for Class I applications.**

## Class II Pressurization Set-up

1. Close the Enclosure Pressure Control Regulator fully, by turning it counterclockwise (CCW).
2. Remove all traces of combustible dust from the protected enclosure.
3. Check operation of Enclosure Protection Vent (if utilized).
4. Seal enclosure(s) and adjust Enclosure Pressure Control Regulator by opening slowly clockwise (CW) to set a “Safe” pressure on the Enclosure Pressure Indicator.
5. Install and tighten all bolts on the pressure loss alarm switch (if utilized). Ensure the conduit is sealed with approved compounds. Energize power to Switch and alarm system (if utilized) and test the function of the alarm system.

**NOTE:** If pressure setting is difficult to stabilize or set, (see page 17, “Trouble-Shooting Procedures”).

# Operating Sequence

## WARNING

Do not exceed a "Safe" pressure with the Enclosure Pressure Control Regulator.

Operators must follow step-by-step sequence of the Start-Up Instructions Nameplate on the Protection System.

### Class I Purging Operation

#### Start-Up Conditions

**Protection Method:** Type "Z" Purge/Pressurization System  
**Powering Method:** Local Disconnect Switch  
**System Status:** Protected Equipment De-energized  
 Alarm System and Air Supply On

#### Operating Procedures

1. Check operation of enclosure pressure relief device (if utilized) and seal the protected enclosure.
2. Pressurize the protected enclosure to set and maintain a minimum positive pressure of 0.10 inches (2.5 mm) of water.
3. Exchange the recommended volumes of purging gas.  
 Exception: Power may be energized immediately if the protected enclosure atmosphere is known to be nonflammable.
4. Energize the protected equipment power manually with a disconnect switch or breaker rated for the hazardous location.
5. Loss of pressurization requires immediate attention or the manual de-energizing of protected equipment power.
6. Excessively hot equipment must be isolated in a separate protected enclosure, unless the enclosure is marked with a warning which indicates a required cool-down time period before access.

### Class II Pressurization Operation

#### Start-Up Conditions

**Protection Method:** Type "Z" Pressurization System  
**Powering Method:** Local Disconnect Switch  
**System Status:** Protected Equipment De-energized  
 Alarm System and Air Supply On

#### Operating Procedures

1. Remove hazardous substance from the protected enclosure. A vacuum device is the preferred tool for dust removal.
2. Check operation of enclosure pressure relief device (if utilized) and seal the protected enclosure.
3. Pressurize the protected enclosure to set and maintain a positive pressure of 0.50 inches (12.7 mm) of water.
4. Energize the protected equipment power manually with a disconnect switch or breaker rated for the hazardous location.
5. Loss of pressurization requires immediate attention or the manual de-energizing of protected equipment power.
6. Excessively hot equipment must be isolated in a separate protected enclosure, unless the enclosure is marked with a warning which indicates a required cool-down time period before access.

Model Identification Nameplate

Enclosure Pressure Control Regulator



Enclosure Pressure Gauge

Start - Up Instruction Nameplate

# Trouble - Shooting Procedures

Problem or Fault	Possible Causes	Corrective Action
Enclosure pressure control regulator will not hold a "Safe" pressure.	Leakage around gasketing, covers, seams, piping and tubing connections, conduit connections and electrical conduit seals of the enclosure.	Tighten enclosure latches: Where tightening is not feasible, and gasketing materials are not practical, holes or gaps can be closed with silicone sealant applied from inside the protected enclosure.
Enclosure pressure indicator reading is difficult to stabilize.	Insufficient enclosure leakage or opening of the venturi orifice is crimped too small.	Remove the orifice, cut off the crimped end and ream the tube, then re-crimp and reinstall the tube to note effect. As tube is shortened, reamed, and re-crimped, sensitivity decreases, allowing easier adjustment of setpoint on the enclosure.
Enclosure Pressure Indicator "Drifts" up or down from the "Safe" pressure setting.	Application involves a small, tightly sealed enclosure and/or a fluctuating protective gas supply.	Pre-regulate the protective gas supply upstream of the enclosure protection system to 5 PSI maximum.  For dramatic fluctuations in the protective gas supply, it may be necessary to utilize a self-relieving low flow precision regulator to pre-regulate the protective gas supply.
Enclosure pressure loss alarm switch does not appear to be operating.	Pressure switch is out of calibration.	Calibrate by slowly adjusting counterclockwise to decrease the setpoint, and clockwise to raise the setpoint. (Do not attempt to calibrate the switch until all efforts to make the switch respond properly have failed)
Problems persists, or if the system does not appear to be operating properly.	Persisting problems.	Contact Pepperl+Fuchs Applications/ Customer Service Department at (330) 486-0002 for more information.

This section covers the most common problems documented with these systems. Any problems not covered in this section should be addressed directly to our factory. Please address all service needs to Pepperl+Fuchs, Inc. - Customer Service Department at (330) 486-0002.

# Warranty Terms and Conditions

## PEPPERL+FUCHS STANDARD 24-MONTH WARRANTY

- Limited Warranty.** Pepperl + Fuchs, Inc. ("P+F") warrants Purge Units and components for Purge Units manufactured by P+F ("Product" or "Products") to be free from defects in material and workmanship under Normal Use for a period of twenty-four (24) months from the date of shipment of such Products from P+F's warehouse or place of manufacture (or from P+F's authorized representative or distributor). Only the original purchaser of such Products (the "Customer") shall be entitled to the benefit of the foregoing Limited Warranty. No representative, agent or salesman of P+F is authorized to give or provide any warranty or make any representation contrary to or in addition to the foregoing Limited Warranty.
- Inspection and Claims.** Customer must inspect and test all Products upon receipt. All claims under the Limited Warranty provided herein must be made within thirty (30) days of the discovery of the defect. Customer must obtain shipping instructions from P+F prior to returning any Product, which Product must be returned at Customer's expense in accordance with P+F's instructions.
- Limitations and Exclusions.** "Normal Use" shall mean use and operation within rated capacities, at the correct voltage, and with any required maintenance as provided in the applicable P+F Operating Manuals. The Limited Warranty provided herein does not apply to (i) any Products which have been altered or modified in any way or disassembled by the Customer or anyone else, (ii) any Products which have been subject to misuse, negligence or accident, or improperly installed, changed, substituted or replaced, (iii) any part or component not manufactured by P+F, or (iv) any part or component that is subject to wear or consumption. For parts or components not manufactured by P+F, the Customer or any other user or owner shall have only the warranty provided by the manufacturer of such part or component. The Limited Warranty set forth herein is also subject to the following:
  - (1) The Limited Warranty is limited to electronic and mechanical performance only, as expressly detailed in the product specifications, and does not apply to cosmetic appearance;
  - (2) The Limited Warranty shall not apply to any cables attached to, or integrated with, any Products.
  - (3) The Limited Warranty shall not apply to any Products which are stored, or utilized, in harsh environmental or electrical conditions outside P+F's written specifications.

THE LIMITED WARRANTY SET FORTH HEREIN IS THE ONLY WARRANTY MADE BY P+F WITH RESPECT TO THE PRODUCTS. IT IS EXPRESSLY AGREED AND UNDERSTOOD THAT P+F MAKES NO WARRANTY OF MERCHANTABILITY OR FITNESS FOR A PARTICULAR PURPOSE. EXCEPT FOR THE LIMITED WARRANTY SET FORTH HEREIN, THERE IS NO OTHER WARRANTY, EXPRESS, IMPLIED OR STATUTORY; AND THERE IS NO AFFIRMATION OF FACT OR PROMISE BY P+F WITH REFERENCE TO THE PRODUCTS. IN NO EVENT SHALL P+F BE LIABLE FOR ACTUAL OR ANTICIPATED LOST PROFITS OR FOR INCIDENTAL OR CONSEQUENTIAL OR PUNITIVE DAMAGES OR FOR DAMAGES RESULTING FROM BUSINESS INTERRUPTION, OR INJURY OR DEATH OF PERSONS, OR INJURY TO PROPERTY. P+F'S LIABILITY ON ANY CLAIM OF ANY KIND ARISING OUT OF, CONNECTED WITH OR RESULTING FROM THE DESIGN, MANUFACTURE, SALE, REPAIR OR OPERATION OF A PRODUCT, SHALL NOT EXCEED THE PRICE ALLOCABLE TO THAT PRODUCT OR THE PART THEREOF WHICH GIVES RISE TO THE CLAIM. THE REMEDY SET FORTH IN THIS LIMITED WARRANTY CONSTITUTES THE SOLE AND EXCLUSIVE REMEDY OF THE CUSTOMER. P+F SHALL NOT BE LIABLE FOR PENALTIES OF ANY DESCRIPTION.

- Limitation of Remedies.** In the event of P+F's liability, whether on this Limited Warranty or based on contract, tort (including, but not limited to, negligence and strict liability) or otherwise, Customer's sole and exclusive remedy will be limited to, at P+F's option, the repair or replacement (f/o/b P+F's place of manufacture) by P+F of any non-conforming items for which claim is made by Customer in accordance with paragraph 2, or the repayment of the portion of the purchase price paid by Customer attributable to the non-conforming item.
- Responsibility of Customer: Safety and Protection Precautions.** P+F takes great care to design and build reliable and dependable Products; however, some Products can fail eventually. Customer must take precautions to design its equipment to prevent property damage and personal injury in the unlikely event of a failure. AS A MATTER OF POLICY, P+F DOES NOT RECOMMEND THE INSTALLATION OF PRODUCTS AS THE SOLE DEVICE FOR THE PROTECTION OF PERSONNEL OR PROPERTY AND, THEREFORE, THE CUSTOMER SHOULD BUILD IN REDUNDANCY OR DUAL CONTROL USING APPROVED SAFETY DEVICES FOR THESE APPLICATIONS.
- Conflicts.** In the event there is any conflict between the provisions of this Limited Warranty and any provisions contained in any orders, offers, acceptances or other writings or statements provided or made by Customer to P+F, the provisions of this Limited Warranty shall prevail, and the contract between P+F and the Customer shall be deemed formed only upon the provisions set forth in this Limited Warranty, and any additional or conflicting provision inserted by Customer shall be of no force or effect.



SYSTEMS IDENTIFICATION & APPLICATION INFORMATION	
Date of Installation	_____
Unit Serial #	_____
Item	_____
Customer P.O.#	_____
Customer Project#	_____
Service	_____
Type	_____
Features	_____
Application	_____

NOTES: \_\_\_\_\_

\_\_\_\_\_

\_\_\_\_\_

\_\_\_\_\_

\_\_\_\_\_

\_\_\_\_\_

Local Sales Representative
_____